

TOP VIEW

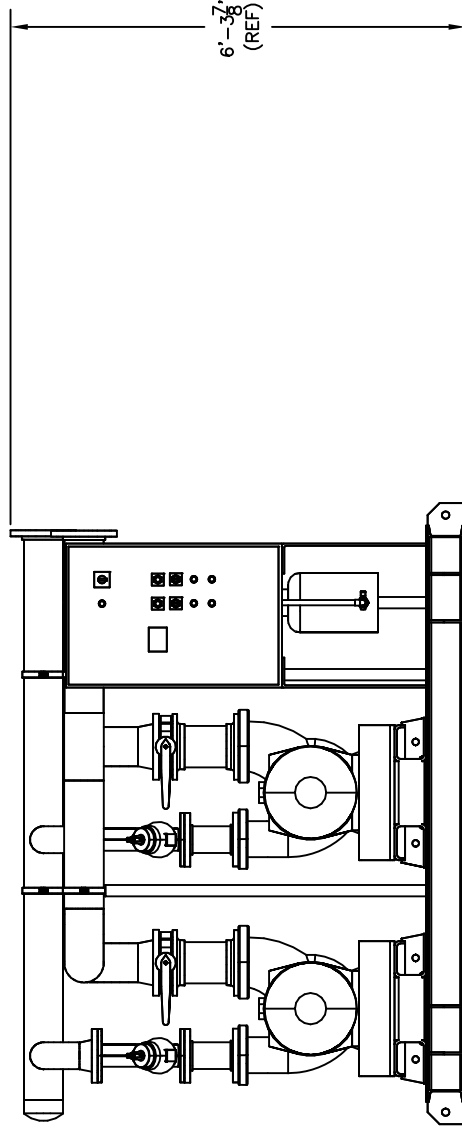

FRONT VIEW

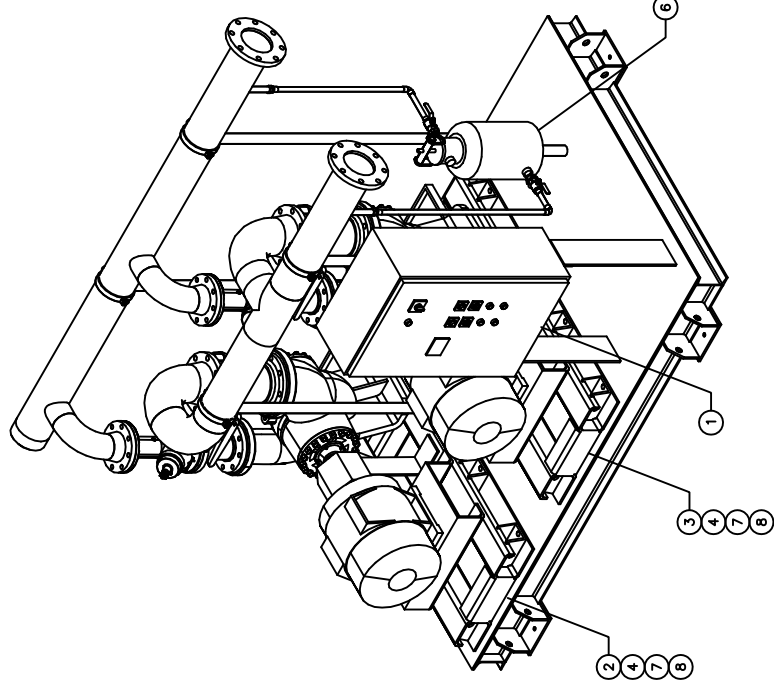
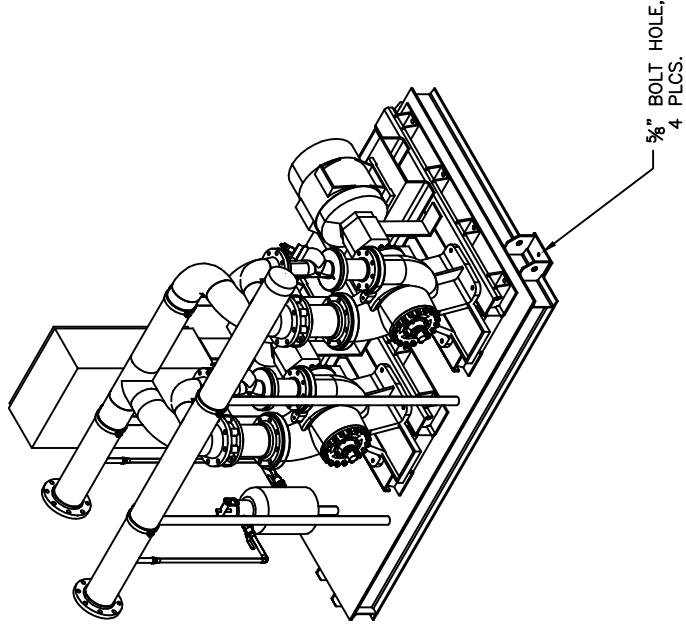
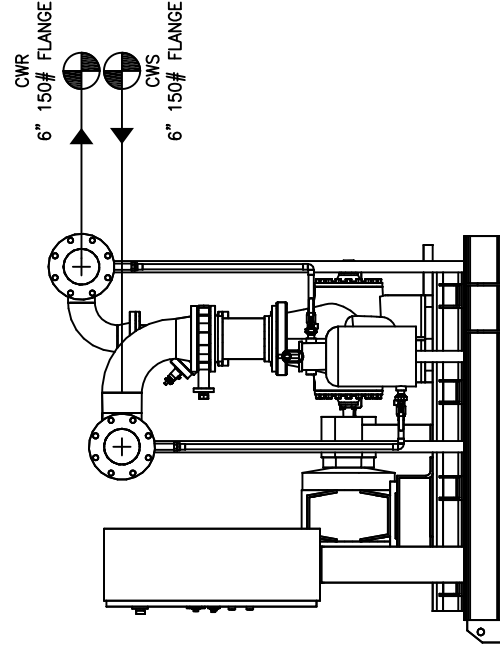

RIGHT END VIEW

DESIGN NOTES:

- (1) COMPLETE SYSTEM TO BE HYDRO TESTED TO 125 PSI PRIOR TO SHIPPING.
- (2) STEEL FRAME AND COMPONENTS TO RECEIVE TWO COATS OF GRAY MACHINE ENAMEL.
- (3) ALL WELDED WATER PIPING TO BE WELDED IN ACCORDANCE TO ASME B31.9
- (4) COMPLETE PACKAGE SYSTEM TO BE UL LISTED.

☉ = DENOTES CONTRACTOR POINT OF CONNECTION

THIS DRAWING AND THE INFORMATION OF DEPICTED THEREIN IS THE PROPERTY OF FLOWTHERM SYSTEMS, A DIVISION OF CALIFORNIA HYDRONICS CORP. COPIES ARE ISSUED IN STRICT CONFIDENCE AND SHALL NOT BE REPRODUCED OR COPIED, OR USED FOR ANY PURPOSES WITHOUT THE WRITTEN PERMISSION OF CALIFORNIA HYDRONICS CORP.



APPROXIMATE SHIPPING WEIGHT: - LBS.
APPROXIMATE OPERATING WEIGHT: - LBS.

JOB NAME: _____
CONTRACTOR: _____

DRWN. _____ DATE _____ CKD. _____ APPROVED _____

TOLERANCES UNLESS OTHERWISE SPECIFIED
DEC. .500" FRACTION 1/2" ANGLE 5" SCALE _____



DRAWING TITLE: PUMPING PACKAGE

FAB No. _____ DRAWING No. _____

REV _____

REV	DESCRIPTION	BY	DATE
-	-	-	-