

TOP VIEW

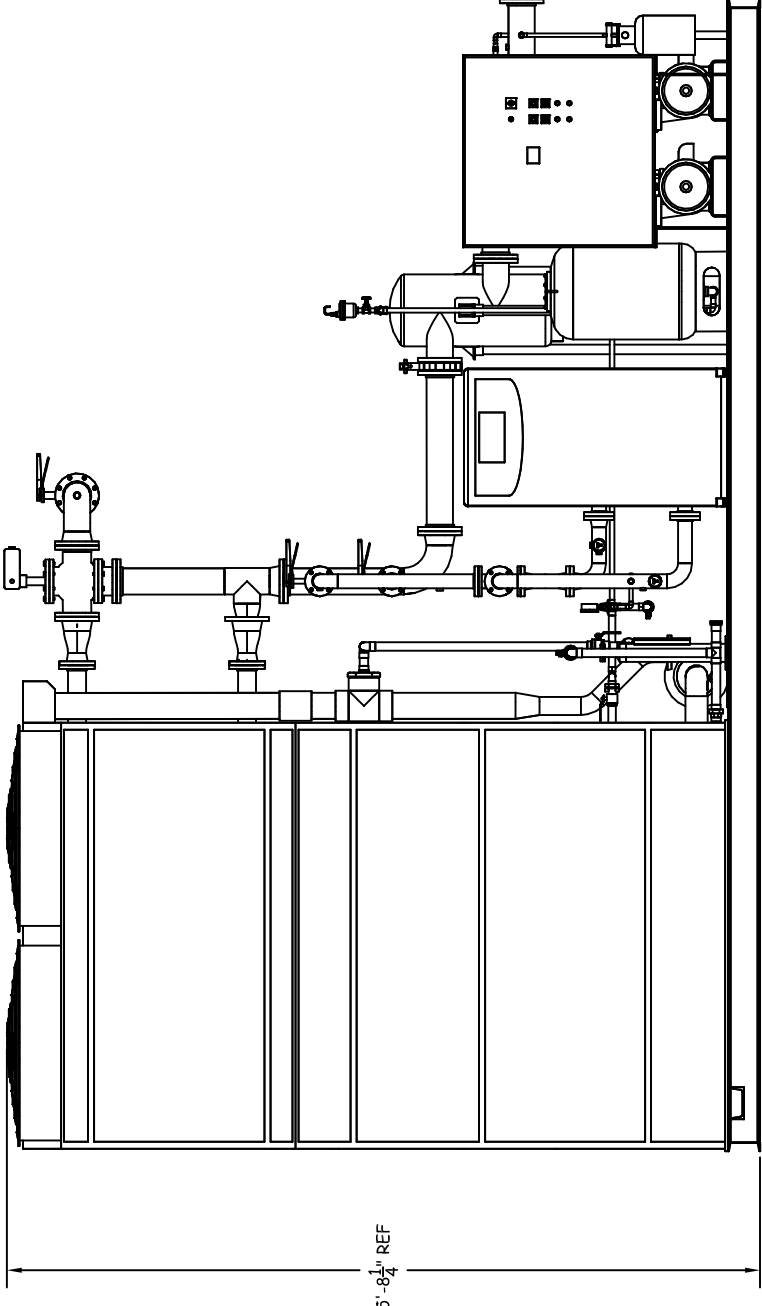
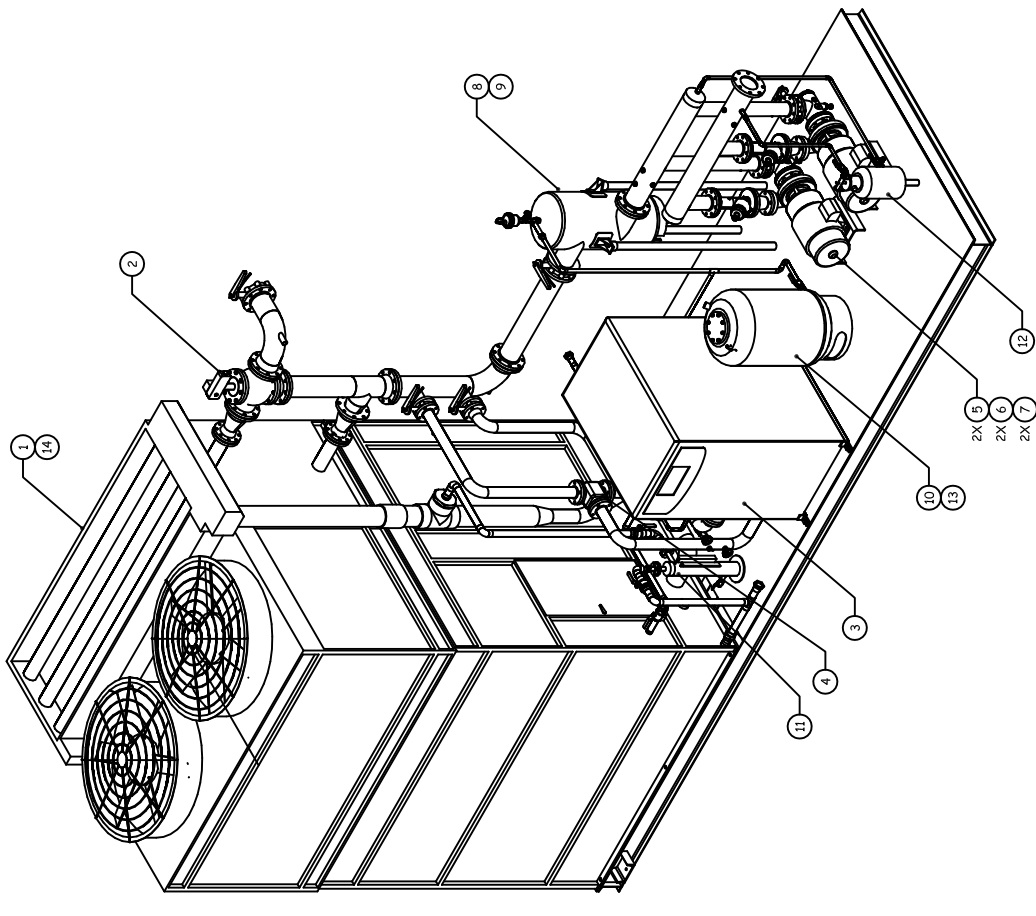

FRONT VIEW

DESIGN NOTES:

- (1) COMPLETE SYSTEM TO BE HYDRO TESTED TO 125 PSI PRIOR TO SHIPPING.
- (2) STEEL FRAME AND COMPONENTS TO RECEIVE TWO COATS OF GRAY MACHINE ENAMEL.
- (3) ALL WELDED WATER PIPING TO BE WELDED IN ACCORDANCE TO ASME B31.9
- (4) COMPLETE PACKAGE SYSTEM TO BE UL LISTED.

☉ = DENOTES CONTRACTOR POINT OF CONNECTION



THIS DRAWING AND THE INFORMATION CONTAINED HEREIN ARE THE PROPERTY OF FLOWTHERM SYSTEMS, A DIVISION OF CALIFORNIA HYDRONICS CORP. COPIES ARE ISSUED IN STRICT CONFIDENCE AND SHALL NOT BE REPRODUCED OR COPIED, OR USED AS THE BASIS FOR THE MANUFACTURING OR SALE OF PRODUCT WITHOUT PRIOR WRITTEN PERMISSION OF CALIFORNIA-HYDRONICS CORP.

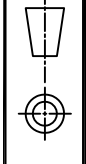

APPROXIMATE SHIPPING WEIGHT: LBS.
APPROXIMATE OPERATING WEIGHT: LBS.

JOB NAME: _____
CONTRACTOR: _____

DRWN.	DATE	CKD.	APPROVED
DEC.	FAC.	ANGLE	SIZE
.500"	1/2"	5°	D

TOLERANCES UNLESS OTHERWISE SPECIFIED

FlowTHERM Systems

DRAWING TITLE: **WATER SOURCE HEAT PUMP PACKAGE**

DRAWING No. (14-123) FTH-P TOP OF THE MOUNDS (SD)

FAB No. _____

REV _____